



# Powerzone Technologies Pte Ltd

**Generator sets powered by Perkins engine**

**Prime: 1710KVA/1368KW  
Standby: 1880KVA/1504KW**



## POWER THAT NEVER FAILS

Founded in 2009, Powerzone Technologies Pte Ltd specialized in the manufacturing of power generator sets and power plant solutions provider.

Powerzone Technologies is one of the leading power generation solution providers in Singapore, supplying High-Quality generator sets, and spare parts to a wide range of industries worldwide.

Our engines are supplied by the world's largest engine manufacturers, namely Perkins and Cummins as well as Caterpillar, MTU and Mitsubishi.

Designed to provide reliable power even in the most extreme climates and performed above and beyond expectations in ambient testing.

Custom designed and built to reduce service & maintenance costs.

## Technical Data

### Generator Set Model: PZ-1710P

Prime power (kVA/kW)	1710/1368
Standby power (kVA/kW)	1880/1504
Rated voltage line to line (V)	230/400
Rated current (A)	2462.4
Maximum sound level (dBA@7m)	75

### Cummins Engine Model: 4012-46TAG3A

Aspiration	4 Stroke, vee 60°C, turbo charged
Fuel system	Direct injection
Number of cylinders	12
Displacement (L)	45.842
Bore*Stroke (mm)	160x190
Compression ratio	13.6:1
Rated speed (r/min)	1500
Governor	Electric
Engine net weight (kg)	4604
Firing order	1a-6b-5a-2b-3a-4b-6a-1b-2a-5b-4a-3b
Start motor (V)	24

### Lubrication System

Oil capacity (L)	177
------------------	-----

### Cooling System

Total coolant capacity (L)	201
----------------------------	-----

### Standard Features

Perkins engine, radiator 50°C max, cooling fans are driven by fan belt, 12V charge alternator

24V charge alternator, single bearing alternator IP23

Insulation class H/H, standard auto control system

Main line circuit breaker / ACB, base fuel tank, 12V batteries, rac and cable

Exhaust system(Ripple flex exhaust pipe), Exhaust siphon, flange, muffler

User manual, battery charge



# Powerzone Technologies Pte Ltd

**Generator sets powered by Perkins engine**

**Prime: 1710KVA/1368KW  
Standby: 1880KVA/1504KW**

## Options

Water heater, alternator heater, PMG, water oil separator, daily fuel tank, remote control panel,

One set of air filter, fuel filter, oil filter, Automatic Transfer Switch (ATS), switch box

## Alternator

Model	PI734D
Alternator brand	Stamford
Phase	3
Voltage (V)	230/400
Wiring type	12 wires
Bearing	1
Power factor	0.8
Frequency (Hz)	50
Prime power (kVA)	1650
Exciter type	Brushless, self-excitation
Voltage regulation (%)	±0.5
Protection grade	IP 23
Insulation grade	Class H

## Controller-Deepsea

Model

DSE 7320

Comprehensive synchronising & loadsharing

Built-in governor and AVR control

Base load (kW export) functionality

Mains (utility) de-coupling protection

Generator power (kW, kVA) monitoring

Overload (kW & kVAR) protection

Emergency stop, Auto-Main-Failure (AMF)



## Generator Set Dimension (Basic unit)

### Open Type

**L\*W\*H (mm) : 5500x2250x2355  
Weight (kg) : 9500**

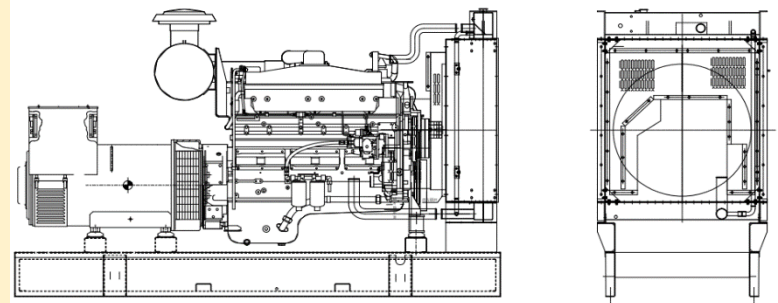

### Silent Type

**L\*W\*H (mm) : 12032x2352x2898  
Weight (kg) : 13500**

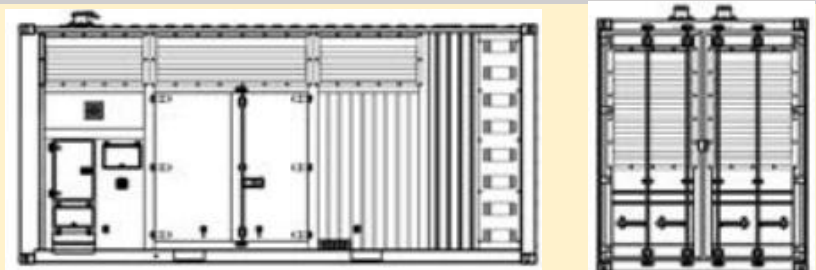

## Warranty

Perkins Engine

12 months from date of delivery.

Generator

12 months from date of delivery.

## Powerzone Technologies Pte Ltd

Blk 9, Kallang Place #06-09

Kallang Basin Industrial Estate Singapore 33915

Tel: +65-6299 3711 Fax: +65-6299 4911

Email : sales@powerzone.com.sg

Website : www.powerzone.com.sg