



Powerzone Technologies Pte Ltd

Generator sets powered by Perkins engine

**Prime: 13KVA/10KW
Standby: 14KVA/11KW**



POWER THAT NEVER FAILS

Founded in 2009, Powerzone Technologies Pte Ltd specialized in the manufacturing of power generator sets and power plant solutions provider.

Powerzone Technologies is one of the leading power generation solution providers in Singapore, supplying High-Quality generator sets, and spare parts to a wide range of industries worldwide.

Our engines are supplied by the world's largest engine manufacturers, namely Perkins and Cummins as well as Caterpillar, MTU and Mitsubishi.

Designed to provide reliable power even in the most extreme climates and performed above and beyond expectations in ambient testing.

Custom designed and built to reduce service & maintenance costs.

Technical Data

Generator Set Model: PZ-13P

Prime power (kVA/kW)	13/10
Standby power (kVA/kW)	14/11
Rated voltage line to line (V)	230/400
Rated current (A)	18
Maximum sound level (dBA@7m)	68

Perkins Engine Model: 403A-15G1

Aspiration	Four-stroke, water-cooled, in line, natural aspirated
Fuel system	Direct injection
Number of cylinders	3
Displacement (L)	1.496
Bore*Stroke (mm)	84x90
Compression ratio	22.5:1
Rated speed (r/min)	1500
Governor	Mechanical
Engine net weight (kg)	197
Firing order	1-2-3
Start motor (V)	12
Lubrication System	
Oil capacity (L)	6
Cooling System	
Total coolant capacity (L)	6

Standard Features

Perkins engine, radiator 50°C max, cooling fans are driven by fan belt, 12V charge alternator

24V charge alternator, single bearing alternator IP23

Insulation class H/H, standard auto control system

Main line circuit breaker / ACB, base fuel tank, 12V batteries, rac and cable

Exhaust system(Ripple flex exhaust pipe), Exhaust siphon, flange, muffler

User manual, battery charge



Powerzone Technologies Pte Ltd

Generator sets powered by Perkins engine

**Prime: 13KVA/10KW
Standby: 14KVA/11KW**

Options

Water heater, alternator heater, PMG, water oil separator, daily fuel tank, remote control panel,

One set of air filter, fuel filter, oil filter, Automatic Transfer Switch (ATS), switch box

Alternator

Model	S0L1-L1
Alternator brand	Stamford
Phase	3
Voltage (V)	230/400
Wiring type	12 wires
Bearing	1
Power factor	0.8
Frequency (Hz)	50
Prime power (kVA)	12.5
Exciter type	Brushless, self-excitation
Voltage regulation (%)	±0.5
Protection grade	IP 23
Insulation grade	Class H

Controller-Deepsea

- Model
- Comprehensive synchronising & loadsharing
- Built-in governor and AVR control
- Base load (kW export) functionality
- Mains (utility) de-coupling protection
- Generator power (kW, kVA) monitoring
- Overload (kW & kVAR) protection
- Emergency stop, Auto-Main-Failure (AMF)

DSE 6120



Generator Set Dimension (Basic unit)

Open Type

**L*W*H (mm) : 1350*750*1050
Weight (kg) : 500**

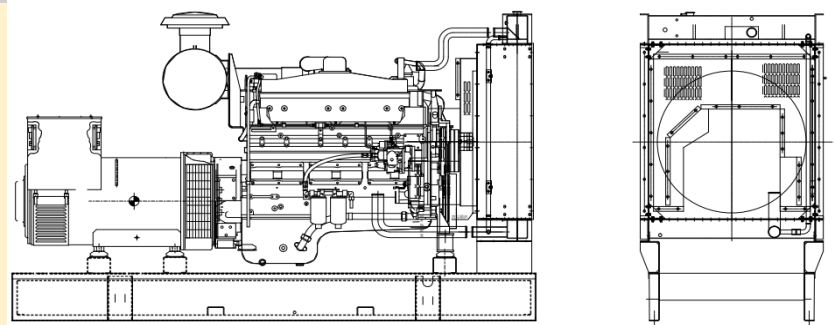

Silent Type

**L*W*H (mm) : 1900*850*1150
Weight (kg) : 700**

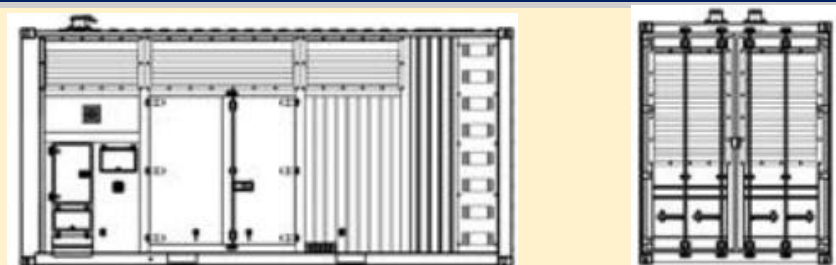

Warranty

Perkins Engine

12 months from date of delivery.

Generator

12 months from date of delivery.

Powerzone Technologies Pte Ltd

B1k 9, Kallang Place #06-09
Kallang Basin Industrial Estate Singapore 33915
Tel: +65-6299 3711 Fax: +65-6299 4911
Email : sales@powerzone.com.sg
Website : www.powerzone.com.sg