



Powerzone Technologies Pte Ltd

Generator sets powered by Perkins engine

**Prime: 10KVA/8KW
Standby: 11KVA/8.8KW**



POWER THAT NEVER FAILS

Founded in 2009, Powerzone Technologies Pte Ltd specialized in the manufacturing of power generator sets and power plant solutions provider.

Powerzone Technologies is one of the leading power generation solution providers in Singapore, supplying High-Quality generator sets, and spare parts to a wide range of industries worldwide.

Our engines are supplied by the world's largest engine manufacturers, namely Perkins and Cummins as well as Caterpillar, MTU and Mitsubishi.

Designed to provide reliable power even in the most extreme climates and performed above and beyond expectations in ambient testing.

Custom designed and built to reduce service & maintenance costs.

Technical Data

Generator Set Model: PZ-10P

Prime power (kVA/kW)	10/8
Standby power (kVA/kW)	11/8.8
Rated voltage line to line (V)	230/400
Rated current (A)	14.4
Maximum sound level (dBA@7m)	68

Perkins Engine Model: 403D-11G

Aspiration	Direct injection
Fuel system	3
Number of cylinders	1.131
Displacement (L)	77x81
Bore*Stroke (mm)	23.0:1
Compression ratio	1500
Rated speed (r/min)	Mechanical
Governor	776x449x700
Engine net weight (kg)	129.2
Firing order	1-2-3
Start motor (V)	12

Lubrication System

Oil capacity (L)	4.9
------------------	-----

Cooling System

Total cooling capacity (L)	5.2
----------------------------	-----

Standard Features

Perkins engine, radiator 50°C max, cooling fans are driven by fan belt, 12V charge alternator

24V charge alternator, single bearing alternator IP23

Insulation class H/H, standard auto control system

Main line circuit breaker / ACB, base fuel tank, 12V batteries, rac and cable

Exhaust system(Ripple flex exhaust pipe), Exhaust siphon, flange, muffler

User manual, battery charge



Powerzone Technologies Pte Ltd

Generator sets powered by Perkins engine

**Prime: 10KVA/8KW
Standby: 11KVA/8.8KW**

Options

Water heater, alternator heater, PMG, water oil separator, daily fuel tank, remote control panel,
One set of air filter, fuel filter, oil filter, Automatic Transfer Switch (ATS), switch box

Alternator

Model	S0L1-H1
Alternator brand	Stamford
Phase	3
Voltage (V)	230/400
Wiring type	12 wires
Bearing	1
Power factor	0.8
Frequency (Hz)	50
Prime power (kVA)	10
Exciter type	Brushless, self-excitation
Voltage regulation (%)	±0.5
Protection grade	IP 23
Insulation grade	Class H

Controller-Deepsea

Model **DSE 6120**

Comprehensive synchronising & loadsharing
Built-in governor and AVR control
Base load (kW export) functionality
Mains (utility) de-coupling protection
Generator power (kW, kVA) monitoring
Overload (kW & kVAR) protection
Emergency stop, Auto-Main-Failure (AMF)



Generator Set Dimension (Basic unit)

Open Type

**L*W*H (mm) : 1350*750*1050
Weight (kg) : 420**

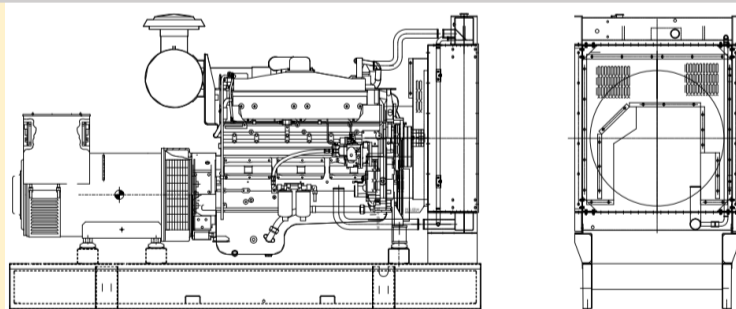

Silent Type

**L*W*H (mm) : 1900*850*1150
Weight (kg) : 620**

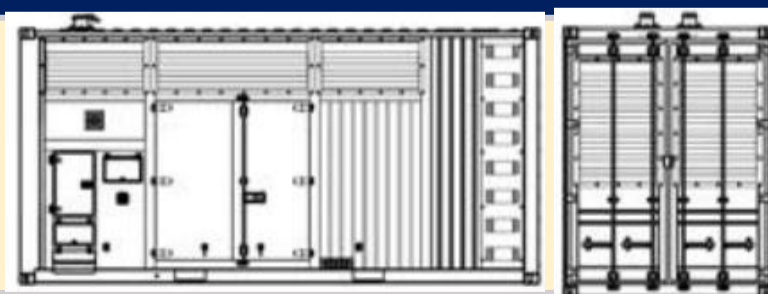

Warranty

Perkins Engine

12 months from date of delivery.

Generator

12 months from date of delivery.

Powerzone Technologies Pte Ltd

Blk 9, Kallang Place #06-09
Kallang Basin Industrial Estate Singapore 33915
Tel: +65-6299 3711 Fax: +65-6299 4911
Email : sales@powerzone.com.sg
Website : www.powerzone.com.sg