



# Powerzone Technologies Pte Ltd

**Generator sets powered by Cummins engine**

**Prime: 650kVA/520kW  
Standby: 715kVA/572kW**



## POWER THAT NEVER FAILS

Founded in 2009, Powerzone Technologies Pte Ltd specialized in the manufacturing of power generator sets and power plant solutions provider.

Powerzone Technologies is one of the leading power generation solution providers in Singapore, supplying High-Quality generator sets, and spare parts to a wide range of industries worldwide.

Our engines are supplied by the world's largest engine manufacturers, namely Perkins and Cummins as well as Caterpillar, MTU and Mitsubishi.

Designed to provide reliable power even in the most extreme climates and performed above and beyond expectations in ambient testing.

Custom designed and built to reduce service & maintenance costs.

## Technical Data

### Generator Set Model: PZ-650C

Prime power (kVA/kW)	650/520
Standby power (kVA/kW)	715/572
Rated voltage line to line (V)	230/400
Rated current (A)	936
Maximum sound level (dBA@7m)	75

### Cummins Engine Model: QSK19-G4

Aspiration	4 cycle, in-line, 6 cylinders, turbocharged air cooled
Fuel system	Direct Injection Cummins PT
Number of cylinders	6
Displacement (L)	18.9
Bore*Stroke (mm)	159x159
Compression ratio	15.0:1
Rated speed (r/min)	1500
Governor	Electric system
Engine net weight (kg)	1901
Engine idle speed (r/min)	575-650
Firing order	1-5-3-6-2-4
Start motor (V)	24



# Powerzone Technologies Pte Ltd

**Generator sets powered by Cummins engine**

**Prime: 650kVA/520kW  
Standby: 715kVA/572kW**

## Lubrication System

Idle speed oil pressure (kPa)	103
Governed speed oil pressure (kPa)	345-483
Max oil temp (°C)	121
Oil capacity (L)	84.4

## Cooling System

Coolant capacity--Engine only (L)	41.6
Coolant capacity--With radiator	112
Max coolant friction head to engine (kPa)	34.5
Max water temp standby/prime power (°C)	104/100

## Standard Features

- Cummins engine, radiator 50°C max, cooling fans are driven by fan belt
- 24V charge alternator, single bearing alternator IP23
- Insulation class H/H, standard auto control system
- One set of air filter, fuel filter, oil filter, main line circuit breaker / ACB
- Base fuel tank, two 24V batteries, rac and cable, exhaust system (ripple flex exhaust pipe)
- Exhaust siphon, flange, muffler, user manual, battery charger

## Options

- Water heater, alternator heater, PMG, water oil separator, daily fuel tank, remote control panel,
- Automatic Transfer Switch (ATS), switch box

## Alternator

Model	HCI544F
Alternator brand	Stamford
Phase	3
Voltage (V)	230/400
Wiring type	12 wires
Bearing	1
Power factor	0.8
Frequency (Hz)	50
Prime power (kVA)	670
Exciter type	Brushless, self-excitation
Voltage regulation (%)	±0.5
Protection grade	IP 23
Insulation grade	Class H



# Powerzone Technologies Pte Ltd

Generator sets powered by Cummins engine

Prime: 650kVA/520kW  
Standby: 715kVA/572kW

## Controller-Deepsea

### Model

Comprehensive synchronising & loadsharing

Built-in governor and AVR control

Base load (kW export) functionality

Mains (utility) de-coupling protection

Generator power (kW, kVA) monitoring

Overload (kW & kVAR) protection

Emergency stop, Auto-Main-Failure (AMF)

DSE 7320



## Generator Set Dimension (Basic unit)

### Open Type

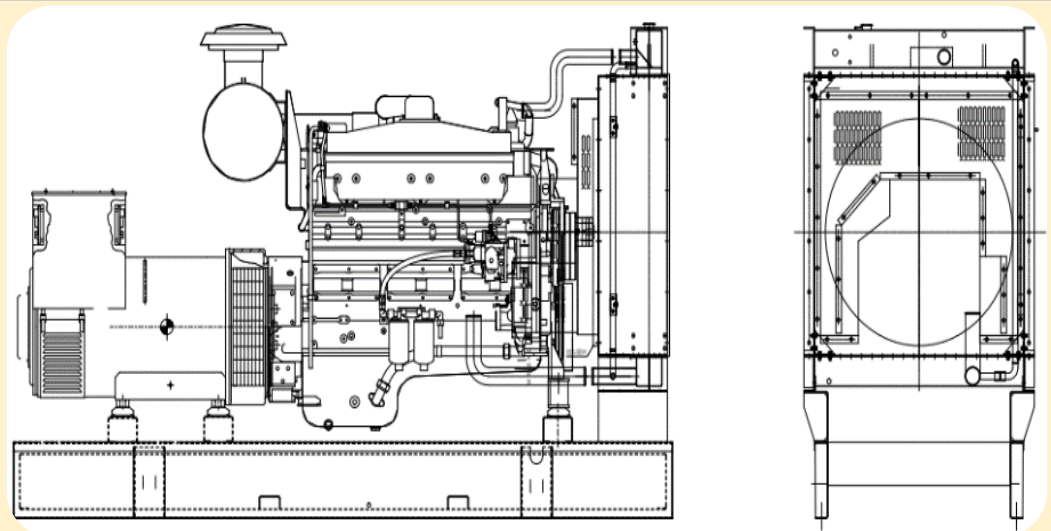

L\*W\*H (mm) : 3700\*1850\*2000  
Weight (kg) : 4200

### Silent Type

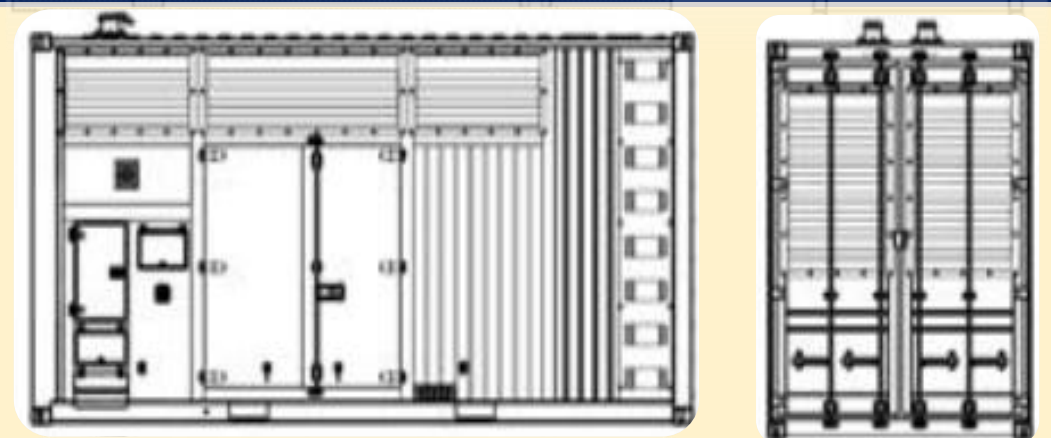

L\*W\*H (mm) : 5000\*2150\*2500  
Weight (kg) : 4800

## Warranty

Cummin Engine

12 months from date of delivery.

Generator

12 months from date of delivery.

## Powerzone Technologies Pte Ltd

Blk 9, Kallang Place #06-09

Kallang Basin Industrial Estate Singapore 33915

Tel: +65-6299 3711 Fax: +65-6299 4911

Email : [sales@powerzone.com.sg](mailto:sales@powerzone.com.sg)

Website : [www.powerzone.com.sg](http://www.powerzone.com.sg)