



# Powerzone Technologies Pte Ltd

**Generator sets powered by Cummins engine**

**Prime: 125kVA/100kW  
Standby: 138kVA/110kW**



## POWER THAT NEVER FAILS

Founded in 2009, Powerzone Technologies Pte Ltd specialized in the manufacturing of power generator sets and power plant solutions provider.

Powerzone Technologies is one of the leading power generation solution providers in Singapore, supplying High-Quality generator sets, and spare parts to a wide range of industries worldwide.

Our engines are supplied by the world's largest engine manufacturers, namely Perkins and Cummins as well as Caterpillar, MTU and Mitsubishi.

Designed to provide reliable power even in the most extreme climates and performed above and beyond expectations in ambient testing.

Custom designed and built to reduce service & maintenance costs.

## Technical Data

### Generator Set Model: PZ-125C

Prime power (kVA/kW)	125/100
Standby power (kVA/kW)	138/110
Rated voltage line to line (V)	230/400
Rated current (A)	180
Maximum sound level (dBA@7m)	73

### Cummins Engine Model: 6BTA5.9-G2

Aspiration	Four-stroke, water-cooled, in-line, direct injection, turbocharged aftercooled
Fuel system	BYC PB electric governor
Number of cylinders	6
Displacement (L)	5.9
Bore*Stroke (mm)	102x120
Compression ratio	17.3:1
Rated speed (r/min)	1500
Governor	Electric system
Engine net weight (kg)	435
Engine idle speed (r/min)	750-850
Firing order	1-5-3-6-2-4
Start motor (V)	24



# Powerzone Technologies Pte Ltd

**Generator sets powered by Cummins engine**

**Prime: 125kVA/100kW  
Standby: 138kVA/110kW**

## Lubrication System

Idle speed oil pressure (kPa)	207
Governed speed oil pressure (kPa)	345
Max oil temp (°C)	121
Oil capacity (L)	16.4

## Cooling System

Coolant capacity--Engine only (L)	10
Max coolant friction head to engine (kPa)	35
Max water temp standby/prime power (°C)	104/100

## Standard Features

Cummins engine, radiator 50°C max, cooling fans are driven by fan belt  
24V charge alternator, single bearing alternator IP23  
Insulation class H/H, standard auto control system  
One set of air filter, fuel filter, oil filter, main line circuit breaker / ACB  
Base fuel tank, two 24V batteries, rac and cable, exhaust system (ripple flex exhaust pipe)  
Exhaust siphon, flange, muffler, user manual, battery charger

## Options

Water heater, alternator heater, PMG, water oil separator, daily fuel tank, remote control panel,  
Automatic Transfer Switch (ATS), switch box

## Alternator

Model	UCI274D
Alternator brand	Stamford
Phase	3
Voltage (V)	230/400
Wiring type	12 wires
Bearing	1
Power factor	0.8
Frequency (Hz)	50
Prime power (kVA)	120
Exciter type	Brushless, self-excitation
Voltage regulation (%)	±0.5
Protection grade	IP 23
Insulation grade	Class H



# Powerzone Technologies Pte Ltd

Generator sets powered by Cummins engine

Prime: 125kVA/100kW  
Standby: 138kVA/110kW

## Controller-Deepsea

Model

DSE 6120

Comprehensive synchronising & load-sharing

Built-in governor and AVR control

Base load (kW export) functionality

Mains (utility) de-coupling protection

Generator power (kW, kVA) monitoring

Overload (kW & kVAR) protection

Emergency stop, Auto-Main-Failure (AMF)



## Generator Set Dimensions (Basic unit)

Open Type

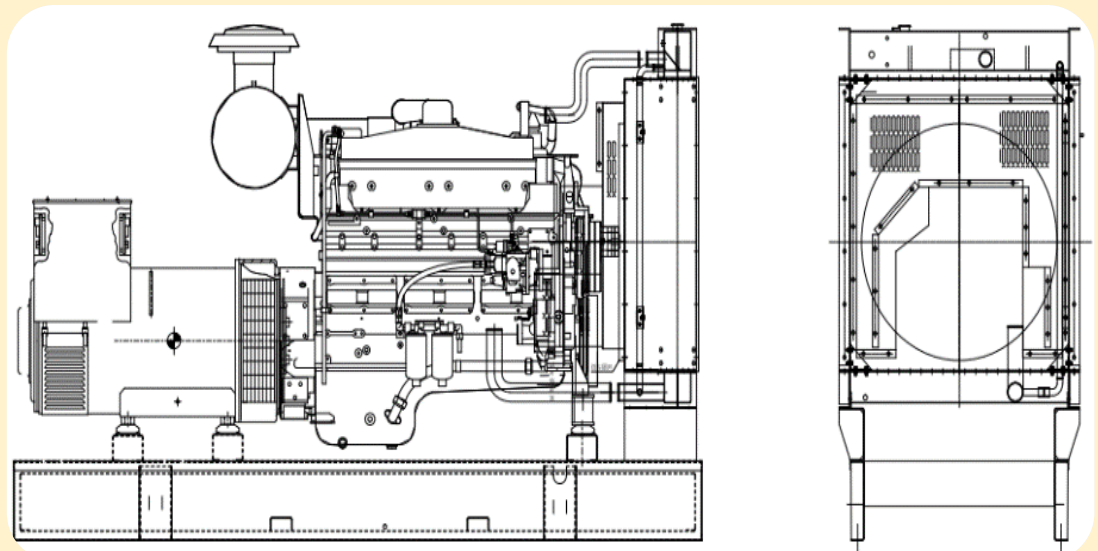

L\*W\*H (mm) : 2200\*950\*1350  
Weight (kg) : 1250

Silent Type

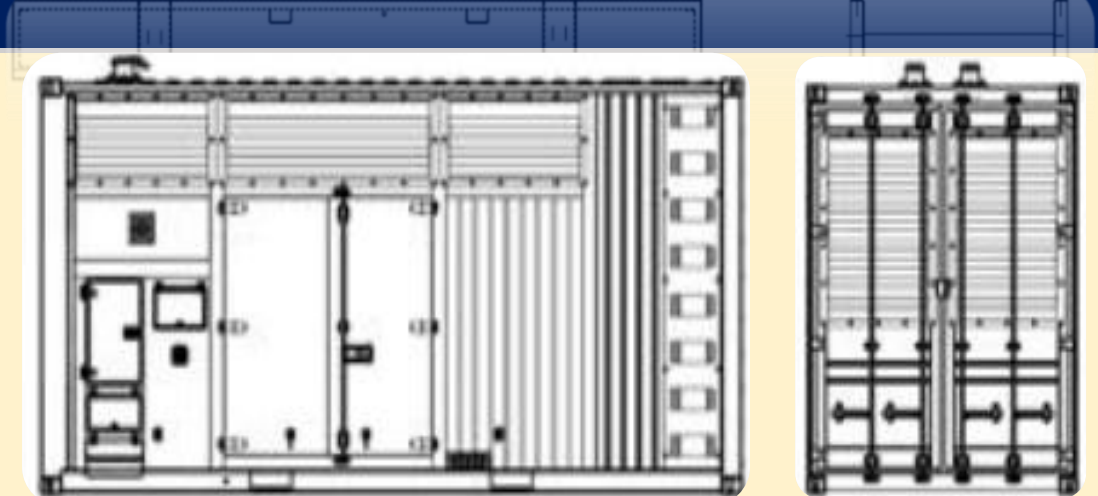

L\*W\*H (mm) : 2850\*1050\*1550  
Weight (kg) : 1650

## Warranty

Cummin Engine

12 months from date of delivery.

Generator

12 months from date of delivery.

## Powerzone Technologies Pte Ltd

Blk 9, Kallang Place #06-09

Kallang Basin Industrial Estate Singapore 33915

Tel: +65-6299 3711 Fax: +65-6299 4911

Email : sales@powerzone.com.sg

Website : www.powerzone.com.sg