



Powerzone Technologies Pte Ltd

Generator sets powered by Cummins engine

**Prime: 1250kVA/1000kW
Standby: 1375kVA/1100kW**



POWER THAT NEVER FAILS

Founded in 2009, Powerzone Technologies Pte Ltd specialized in the manufacturing of power generator sets and power plant solutions provider.

Powerzone Technologies is one of the leading power generation solution providers in Singapore, supplying High-Quality generator sets, and spare parts to a wide range of industries worldwide.

Our engines are supplied by the world's largest engine manufacturers, namely Perkins and Cummins as well as Caterpillar, MTU and Mitsubishi.

Designed to provide reliable power even in the most extreme climates and performed above and beyond expectations in ambient testing.

Custom designed and built to reduce service & maintenance costs.

Technical Data

Generator Set Model: PZ-1250C

Prime power (kVA/kW)	1250/1000
Standby power (kVA/kW)	1375/1100
Rated voltage line to line (V)	230/400
Rated current (A)	1800
Maximum sound level (dBA@7m)	75

Cummins Engine Model: QSK38-G5

Aspiration	60°C V degree , 12 cylinders, turbocharged aftercooled
Fuel system	Direct Injection Cummins PT
Number of cylinders	12
Displacement (L)	37.7
Bore*Stroke (mm)	159x159
Compression ratio	15.0:1
Rated speed (r/min)	1500
Governor	Electric system
Engine net weight (kg)	4100
Engine idle speed (r/min)	575-650
Firing order	1R-6L-5R-2L-3R-4L-6R-1L-2R-5L-4R-3L
Start motor (V)	24



Powerzone Technologies Pte Ltd

Generator sets powered by Cummins engine

**Prime: 1250kVA/1000kW
Standby: 1375kVA/1100kW**

Lubrication System

Idle speed oil pressure (kPa)	138
Governed speed oil pressure (kPa)	344.7-482.6
Max oil temp (°C)	120
Oil capacity (L)	170.3

Cooling System

Coolant capacity--Engine only (L)	106
Coolant capacity--With radiator	300
Max coolant friction head to engine (kPa)	68.9
Max water temp standby/prime power (°C)	104/100

Standard Features

Cummins engine, radiator 50°C max, cooling fans are driven by fan belt
 24V charge alternator, single bearing alternator IP23
 Insulation class H/H, standard auto control system
 One set of air filter, fuel filter, oil filter, main line circuit breaker / ACB
 Base fuel tank, two 24V batteries, rac and cable, exhaust system (ripple flex exhaust pipe)
 Exhaust siphon, flange, muffler, user manual, battery charger

Options

Water heater, alternator heater, PMG, water oil separator, daily fuel tank, remote control panel,
 Automatic Transfer Switch (ATS), switch box

Alternator

Model	LVI634G
Alternator brand	Stamford
Phase	3
Voltage (V)	230/400
Wiring type	12 wires
Bearing	1
Power factor	0.8
Frequency (Hz)	50
Prime power (kVA)	1250
Exciter type	Brushless, self-excitation
Voltage regulation (%)	±0.5
Protection grade	IP 23
Insulation grade	Class H



Powerzone Technologies Pte Ltd

Generator sets powered by Cummins engine

**Prime: 1250kVA/1000kW
Standby: 1375kVA/1100kW**

Controller-Deepsea

Model

DSE 7320

Comprehensive synchronising & loadsharing

Built-in governor and AVR control

Base load (kW export) functionality

Mains (utility) de-coupling protection

Generator power (kW, kVA) monitoring

Overload (kW & kVAR) protection

Emergency stop, Auto-Main-Failure (AMF)



Generator Set Dimension (Basic unit)

Open Type

**L*W*H (mm) : 4600*1900*2050
Weight (kg) : 5800**

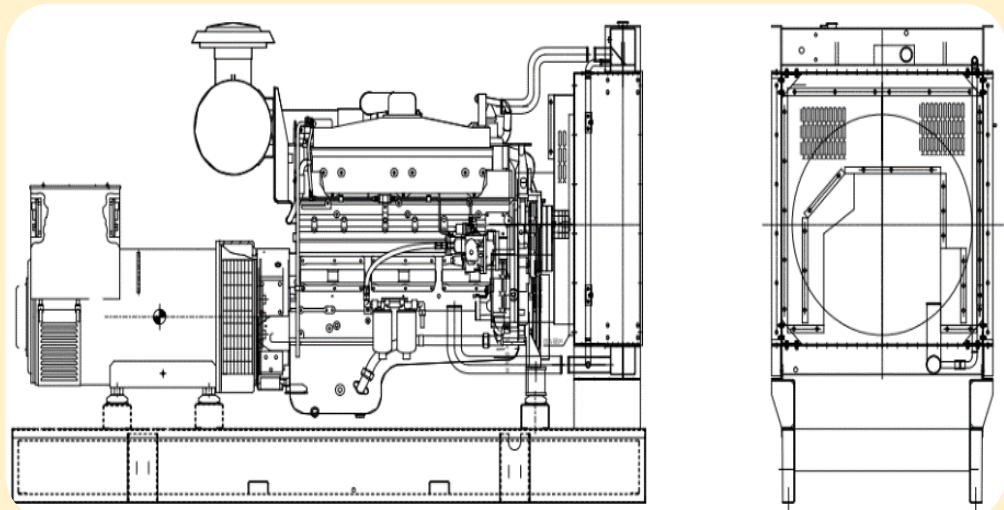

Silent Type

**L*W*H (mm) : 5900*2500*2750
Weight (kg) : 7600**

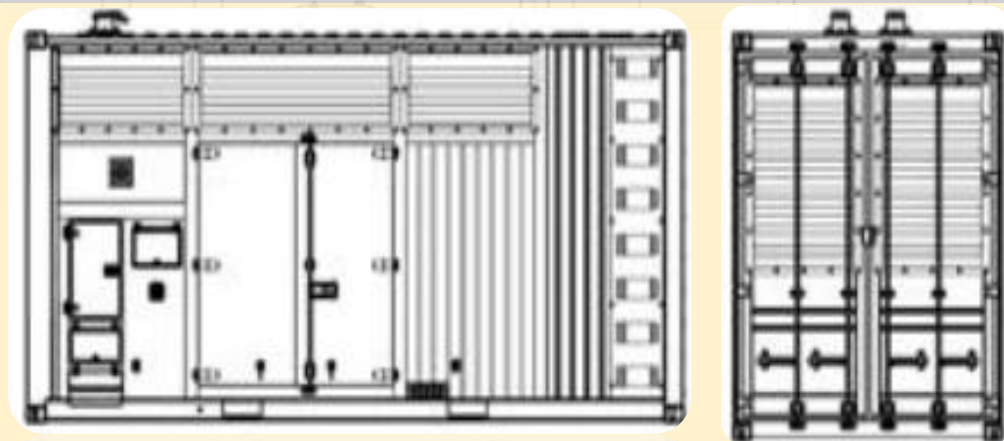

Warranty

Cummin Engine

12 months from date of delivery.

Generator

12 months from date of delivery.

Powerzone Technologies Pte Ltd

Blk 9, Kallang Place #06-09

Kallang Basin Industrial Estate Singapore 33915

Tel: +65-6299 3711 Fax: +65-6299 4911

Email : sales@powerzone.com.sg

Website : www.powerzone.com.sg